

PHD™



Installation Guide

TORCH & CONSUMABLE REPLACEMENT

TORCH & REPLACEABLE PARTS



Torch Body



Quick Disconnect
Receptacle



Sleeve

REPLACEMENT PARTS

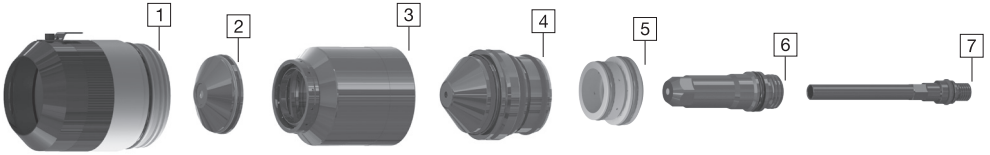

1. Outer Retainer
2. Shield Cap
3. Inner Retainer
4. Nozzle

5. Swirl Ring
6. Electrode
7. Water Tube

CONSUMABLE TOOL



- ≥ 200 Amps Nozzle Removal
- Electrode Removal
- ≤ 130 Amps Nozzle Removal

WATER TUBE TOOL



TORCH BODY

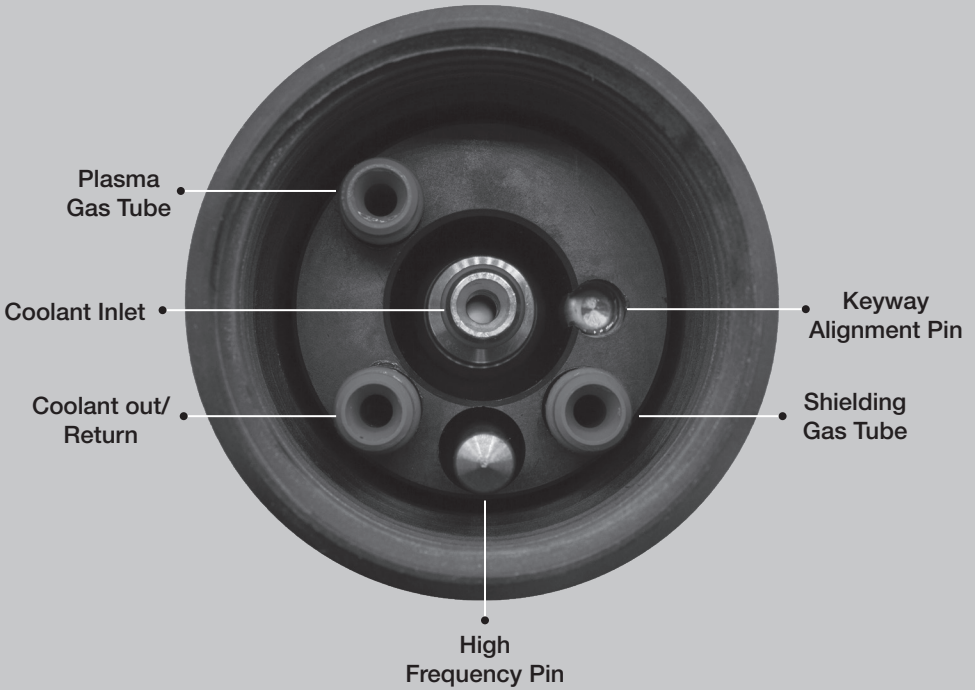

PHD™ Installation



PHD™ INSTALLATION



1

Using provided tool install proper water tube. Make sure it is properly threaded and seated, but not over tightened.



2

Using proper silicone grease, take a small dab and rub between your clean thumb and finger. Grease all O-rings including the flow tubes on the back of the torch. Make sure not to clog holes of the swirl ring.



3

Hand start the threads of the electrode in the torch body and tighten with proper tool. Do not over tighten as this will cause damage to the torch head.

PHD™ INSTALLATION



4

Carefully insert the small side of the swirl ring into the nozzle. It will not go all the way in. Holes should be visible.



5

Insert the nozzle and swirl ring over the electrode and firmly push the nozzle down until O-rings are not visible.



6

Screw the nozzle retaining cap onto the torch body until it bottoms out, do not overtighten or nozzle retainer could be damaged when removed.

PHD™ INSTALLATION

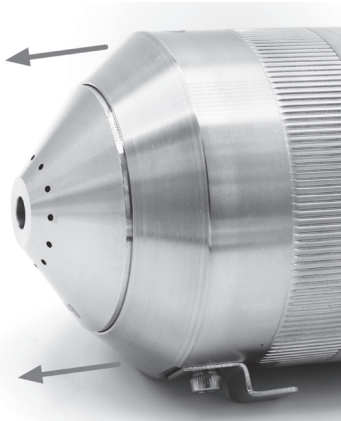

7

Press the shield into the shield cap.

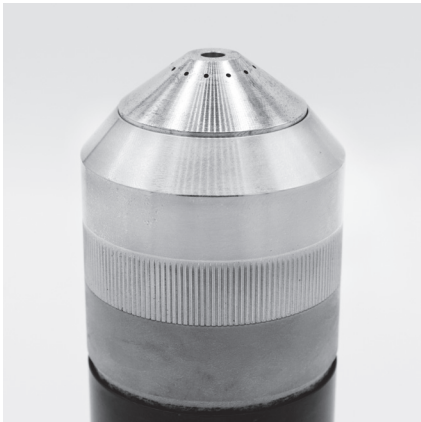

8

Slide shield cap over nozzle retainer until flush, being careful not to cross thread. The cap should be snug to prevent leaking, but not extremely tight which can cause damage when removing.



9

Push on the shield to make sure it does not move.

PHD™ INSTALLATION

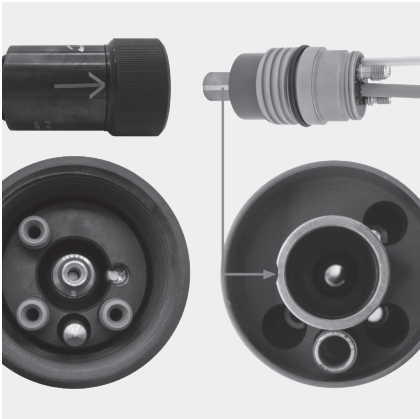

10

Line up arrow on outside of torch body, or the key that is located on top of torch quick disconnect, with the key way on the torch lead stem assembly.



11

Insert torch fully and tighten the quick connect nut until top O-ring is engaged.



12

Purge system. Multiple purges may be required to remove all fluid.

PHD™ Removal



PHD™ REMOVAL



1

Unscrew the plastic nut and pull down to remove torch body from quick disconnect receptacle.

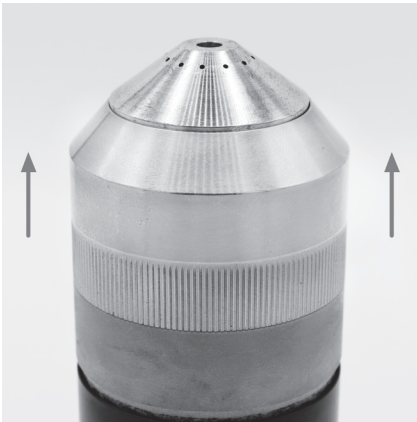

2

Hand loosen shield cap and remove.

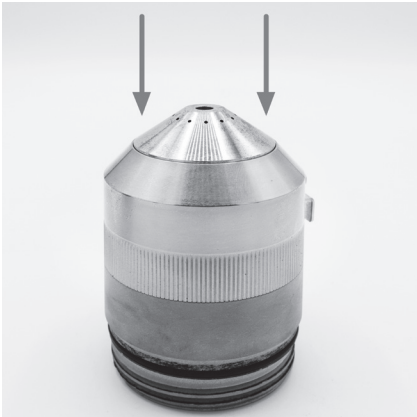

3

Push the shield out of the shield cap.

PHD™ REMOVAL

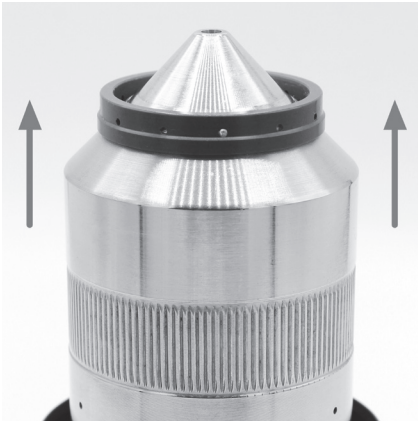

4

Hand loosen nozzle retaining cap and remove.



5

Use consumable tool to pull the nozzle straight up from the torch body.



6

Use consumable tool to unscrew electrode. The swirl ring will also be removed with the electrode.

PHD™ REMOVAL

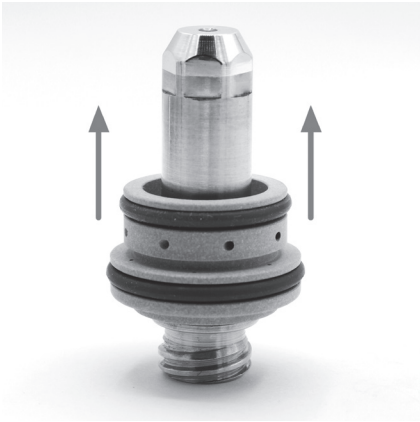

7

Remove swirl ring from electrode.



8

Unscrew water tube using water tube tool.

WARRANTY

American Torch Tip (ATTC) warrants its products to the original end user for the periods listed below:

		180 DAYS	ONE YEAR	THREE YEARS	LIFETIME
PLASMA	* PHD™ & PHDX™ Torch Bodies				●
MIG	* Lightning® Handle & Trigger Switch				●
	* Lightning® Semi-Automatic MIG Guns		●		
	* Lightning® Robotic MIG Guns		●		
	* Lightning® Fixed Automation MIG Guns		●		
	* All Other Gun Models	●			
GAS APPARATUS	* Complete Oxy-Fuel Kit Components			●	
	* Regulators/Flowmeters/Flowregulators			●	
	* Torches, Handles & Cutting Attachments			●	
TIG	* TIG Torches		●		
THERMAL SPRAY	* Thermal Spray Guns		●		

* Limited Warranty on Manufacturing and Material Defects. Warranty Terms Do Not Apply to Consumable Products.

WARRANTY TERMS

This warranty shall not apply to any product that has been modified or used in a manner inconsistent with ATTC's installation instructions and operating guidelines.

Within the warranty periods listed above and at ATTC's sole discretion, ATTC will repair or replace any warranted parts or components that fail due to such defects in material or workmanship. ATTC must be notified within thirty (30) days of such defect or failure, at which time ATTC will determine if a Return Goods Authorization (RGA) is justified and issue an RGA number, authorization of a RGA number shall not be unreasonably withheld.

ATTC will supply a RGA form, which must be included with the returned products for inspection by ATTC. Shipping and packing costs shall be the responsibility of the party returning the goods. Once received, ATTC shall inspect and determine if a warranty claim is justified and at ATTC's sole discretion authorize a repair or replacement.

Once authorization has been granted ATTC shall provide instructions on the warranty claim procedures to be followed. Where authorized, repair or replacement constitutes the sole remedy for breach of warranty and expressly excludes claims for lost revenue, down time and other consequential damages. The warranty is limited to the conditions stated above and excludes, to the fullest extent permitted by law, all conditions, warranties and representations express or implied by statute, law or otherwise in relation to the supply or delay in supplying the goods/services.

There are no agreements, promises or understandings, either verbal or written that are not fully expressed in this warranty. This warranty may be amended or altered only if agreed to in writing and signed by ATTC.

CREATING A BETTER EXPERIENCE



Our mission at American Torch Tip is to create a better experience for our customers and the end users of our products. Creating a better experience is not just a tagline, it's at the heart of everything that we do.

— To that end, we commit to: —



**Always Do The
Right Thing**

We stand by our products with a 100% satisfaction guarantee. Should they not meet your expectations we will do what is in our power to make it right.



**Only Ship Products
That Meet Our
Standards**

Our products are rigorously tested and inspected to meet high standards and ensure the highest quality.



**Deliver The
Greatest Possible
Performance**

We promise that all products manufactured by American Torch Tip will deliver the greatest possible performance for the operator. Offering six (6) welding and cutting platforms; we take our knowledge from each and use it to design the highest quality product.



**Ship In A
Timely Manner**

Any regular item we quote is available to ship within three (3) days unless otherwise stated. We have 6,000 items in stock and ready-to-order but also produce over 20,000 specialty and hard-to-find products every day.

THAT'S THE AMERICAN WAY

The American Way is symbolic of how we've done business as an American manufacturer since 1940. Treating our customers with the utmost respect and servicing their requests to the best of our abilities. Being a family owned company that creates domestic opportunities and employment for hard working Americans. Most of all, creating the best possible products that exceed the expectations of our customers.



PHD[™]
BY AMERICAN TORCH TIP