

OUR GCS-25 PROGRAM



HOW IT WORKS

DEMO

American Torch Tip® will supply CleanCut™ consumables free of charge.

Our plasma technicians will be available any time to assist you during the evaluation process by phone or, if needed, with an in-plant visit.



DOCUMENT

Our team will provide tracking tools allowing for easy documentation of your incumbent product and CleanCut™.

Your only obligation to secure your 25% savings is to share the test results with American Torch Tip®.



SAVE

American Torch Tip® will provide an ROI presentation using your documented results.

American Torch Tip® guarantees your 25% savings using CleanCut™ technology.



AMERICAN TORCH TIP®

6212 29th Street East, Bradenton, FL
P: 941-753-7557
AmericanTorchTip.com

Learn more about CleanCut™ →

CleanCut™

DESIGNED TO WORK TOGETHER

CleanCut™ Electrode

1. Extend Electrode Life

- More efficient cooling
- Extended hafnium electrode life
- 25% – 50% longer production time

2. Prevent Nozzle Damage

- Cooler silver electrodes diminish nozzle damage
- Nozzles paired with silver electrodes last longer

CleanCut™ Nozzle

(patent pending)

3. Supercharge the Plasma Arc

- Smooth-bore configuration reduces turbulence
- Stabilizes and accelerates the plasma arc column
- Produces ultra-smooth cuts

**BURN LONGER.
CUT CLEANER.**

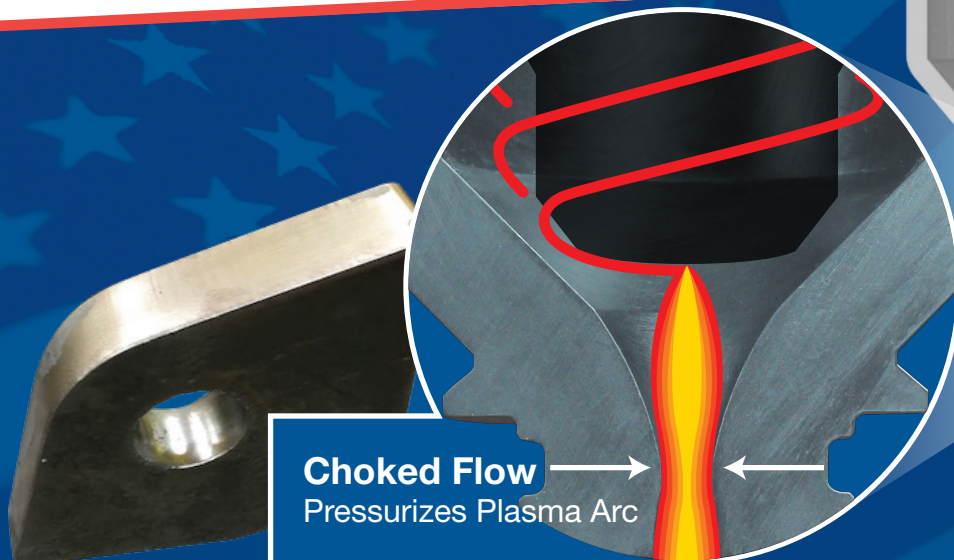
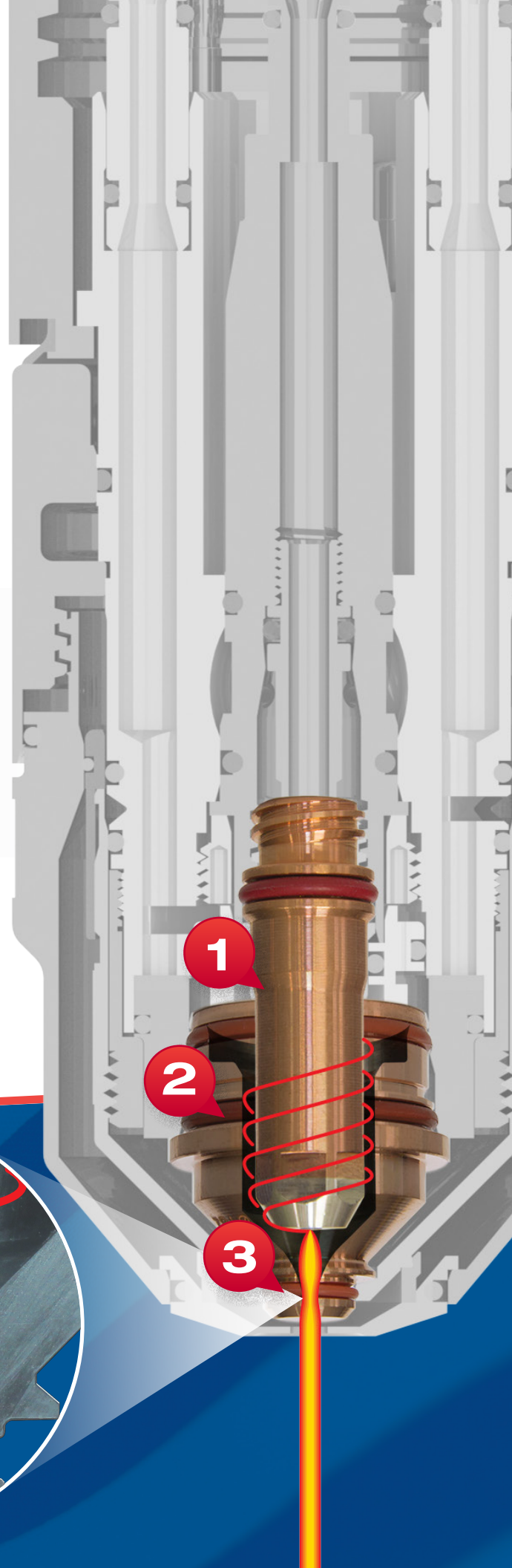

Choked Flow
Pressurizes Plasma Arc