

CLEANCUT™ ELECTRODE

1 Extend Electrode Life

- More efficient cooling
- Extended hafnium electrode life
- 25% – 50% longer production time

2 Prevent Nozzle Damage

- Cooler silver electrodes diminish nozzle damage
- Nozzles paired with silver electrodes last longer

CLEANCUT™ NOZZLE

(patent pending)

3 Supercharge the Plasma Arc

- Smooth-bore configuration reduces turbulence
- Stabilizes and accelerates the plasma arc column
- Produces ultra-smooth cuts

4 Enhance Coolant Exposure

- 3x larger surface area exposed to coolant

ATTC® is a registered trademark of American Torch Tip Co. and may be registered in the United States and/or other countries. All other trademarks are the properties of their respective owners. ATTC is in no way affiliated with ESAB®.



**BURN LONGER.
CUT CLEANER.**

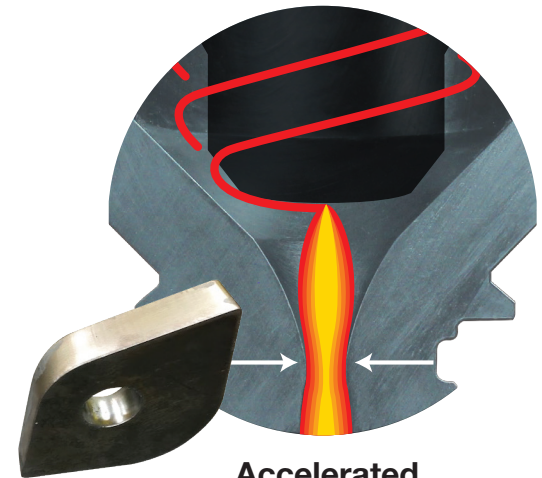

**Accelerated
Nozzle Velocity**

PT-36			
	Pos	Part #	Orifice Size (mm)
Nozzle	1	0558006014ATTC	1.4
		0558006018ATTC	1.8
		0558006020ATTC	2.0
		0558006023ATTC	2.3
		0558006025ATTC	2.5
		0558006030ATTC	3.0
		0558006036ATTC	3.6
Electrode	2	0558003914-AG	
		0558005459-AG	

PT-36XR			
	Pos	Part #	Orifice Size (mm)
Nozzle	3	0558011619ATTC	1.9
		0558011625ATTC	2.5
		0558010722ATTC	2.2
		0558006028ATTC	2.8
Electrode	4	0558012000ATTC	

PT600			
	Pos	Part #	Amp
Nozzle	5	0558001623ATTC	250
		0558001881ATTC	50
		0558001882ATTC	100
		0558001883ATTC	150
		0558001884ATTC	200
		0558001885ATTC	360
		0558001886ATTC	400
		0558001887ATTC	600
Electrode	6	0558001624-AG	250
		0558002516-AG	360

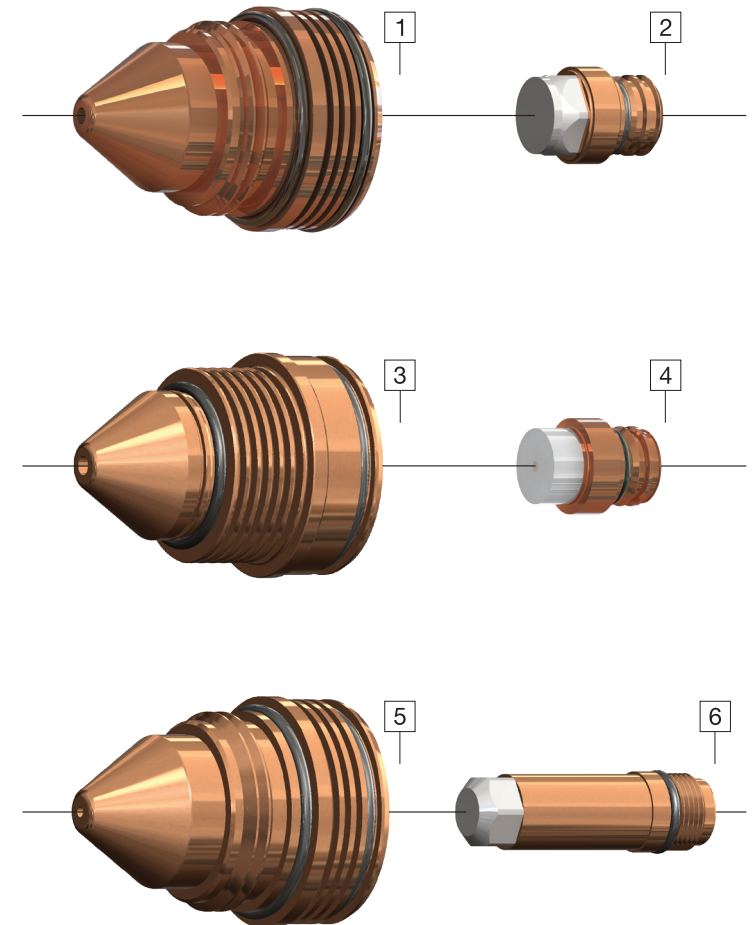

ATTC[®] is a registered trademark of American Torch Tip Co. and may be registered in the United States and/or other countries. All other trademarks are the properties of their respective owners. ATTC is in no way affiliated with ESAB[®].

AMERICAN TORCH TIP[®]

6212 29th Street East, Bradenton, FL
 941-753-7557
 Sales@attcusa.com
 AmericanTorchTip.com

CREATING A BETTER EXPERIENCE

