

CLEANCUT™ ELECTRODE

1 Extend Electrode Life

- More efficient cooling
- Extended hafnium electrode life
- 25% – 50% longer production time

2 Prevent Nozzle Damage

- Cooler silver electrodes diminish nozzle damage
- Nozzles paired with silver electrodes last longer

CLEANCUT™ NOZZLE

(patent pending)

3 Supercharge the Plasma Arc

- Smooth-bore configuration reduces turbulence
- Stabilizes and accelerates the plasma arc column
- Produces ultra-smooth cuts



**BURN LONGER.
CUT CLEANER.**

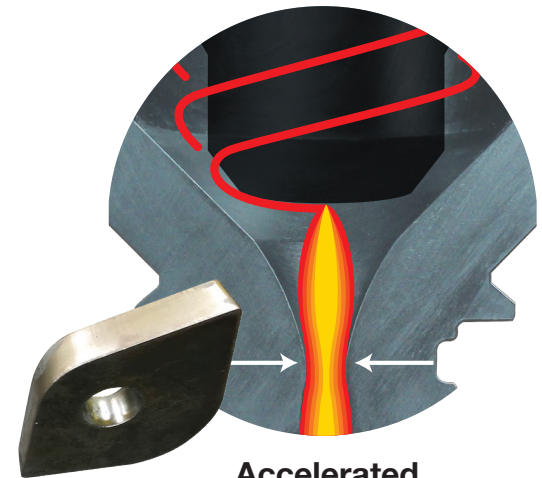

**Accelerated
Nozzle Velocity**

ATTC® is a registered trademark of American Torch Tip Co. and may be registered in the United States and/or other countries. All other trademarks are the properties of their respective owners. ATTC is in no way affiliated with Hypertherm®

AMERICAN TORCH TIP®

6212 29th Street East, Bradenton, FL

941-753-7557

Sales@attcusa.com

AmericanTorchTip.com

**CREATING A BETTER
EXPERIENCE**



Suitable for use with

**HYPERTHERM® HPR130®, HPR260®,
HPR260XD®, HPR400XD®**

NOZZLE		
Pos	Part #	Amp
1	220188ATTC	80
2	220182ATTC	130
3	220354ATTC	200
4	220439ATTC	260
5	220632ATTC	400

ELECTRODE		
Pos	Part #	Amp
6	420566ATTC	80
7	220665ATTC	130
8	220666ATTC	200
9	220668ATTC	260
10	420530ATTC	400

ATTC® is a registered trademark of American Torch Tip Co. and may be registered in the United States and/or other countries. All other trademarks are the properties of their respective owners. ATTC is in no way affiliated with Hypertherm®

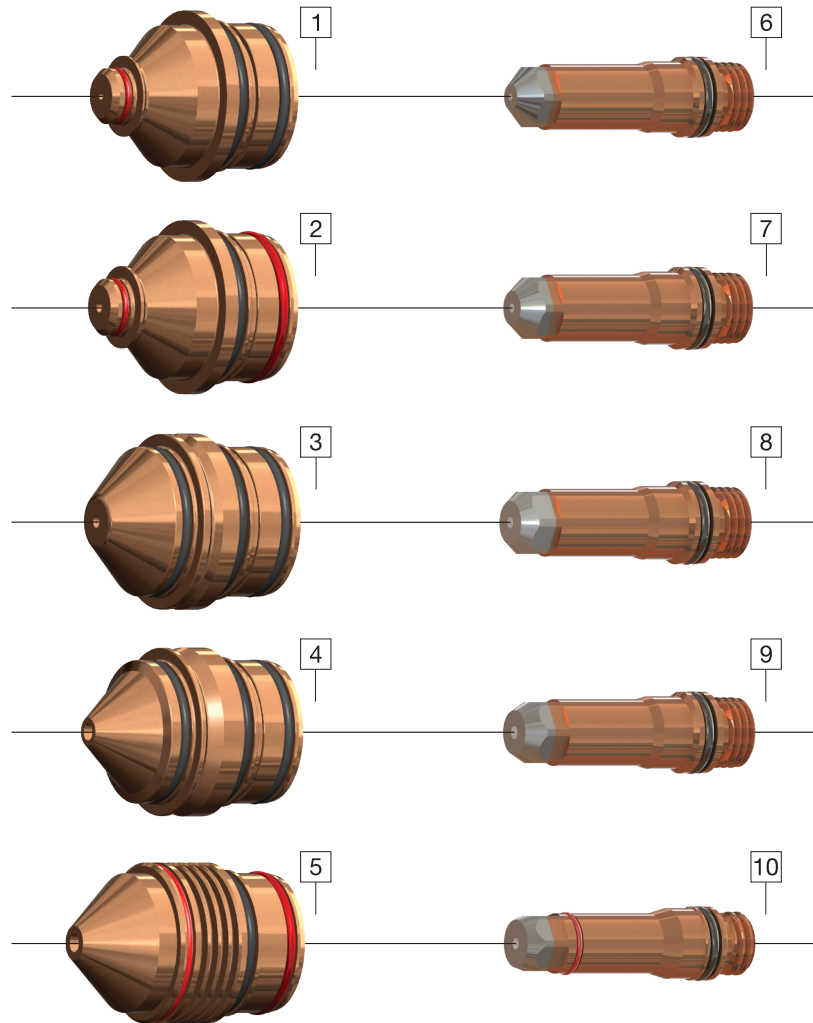

AMERICAN TORCH TIP®

6212 29th Street East, Bradenton, FL
941-753-7557
Sales@attcusa.com
AmericanTorchTip.com

CREATING A BETTER
EXPERIENCE

